



## INSTALLATION INSTRUCTIONS

Read completely before installing

### NOTE 1:

If your vehicle is equipped with vibration dampers between the turns of the coil, it is necessary that these be removed before installing the air springs.

### WARNING:

Do not inflate this assembly when it is unrestricted. The assembly must be restricted by a coil spring. Do not ever inflate beyond recommended operating pressure for your specific vehicle. Improper use or over inflation may cause property damage or severe personal injury.

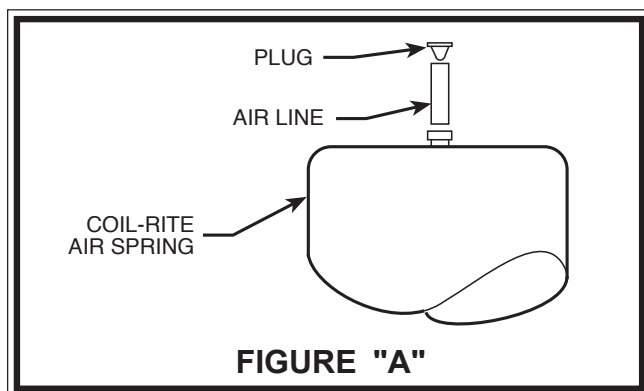

### STEP 1 - PREPARE THE VEHICLE

Remove the negative battery cable. With the vehicle on a solid level surface chock the front wheels. Raise the rear of the vehicle using a lift or platform jack rated for your vehicle's weight. Remove the rear wheels. Lower the vehicle onto jack stands rated for your vehicle's weight, making sure the suspension is fully extended. Do NOT use wood or concrete blocks to support the weight of the vehicle.

### STEP 2 - SHOCK ABSORBERS

If necessary, additional clearance between the coil spring turns may be obtained by removing the shock absorbers from the lower mounts and lowering the suspension an additional one to two inches. Do not put strain or tension on the flexible brake line.

### STEP 3 - PREPARE THE AIR SPRING

Cut a section of air line tubing 3 inches in length and install into the push-to-connect fitting on the air spring. Exhaust the air from the air spring by rolling it up toward the air inlet. After the air has been exhausted, install the plug into the tubing coming out of the air spring see Figure "A".

### STEP 4 - INSTALL THE AIR SPRING

Insert the top of the flattened air spring into the coil spring through the lowest opening of the coil spring with the push to connect air inlet at the bottom of the coil spring see Figure "B".

### STEP 5 - ADJUST THE AIR SPRING

Push the air spring up into the coil spring by hand or with a blunt tool, such as a 1/2" socket extension. Do NOT use any thing with sharp edges or corners, as this may damage the air spring.

When the air spring is completely within the coil spring, remove the plug and tubing from the air spring. The tubing can easily be removed from the air springs. Push the collar on the fitting towards the air spring and pull out the tubing. Allow the air spring to return to its normal shape. Insert the lower support between the air spring and the lower spring seat see Figure "C".

### STEP 6 - REATTACH THE SHOCK ABSORBER

Attach the shock absorber if it was removed earlier in the installation.

### OPERATING PRESSURE RANGE

Minimum - 5psi

Max (loaded) - 35psi

### PARTS LIST

DESCRIPTION	QTY.
AIR SPRING	2
LOWER SUPPORT	2
18' AIR LINE	1
NYLON TIE	6
PUSH-TO-CONNECT INFLATION VALVE	2
PTC PLUGS	2
5/16" FLAT WASHER	4

# COIL-RITE INSTALLATION PROCEDURE

**REPEAT STEPS 3 - 6 FOR THE OPPOSITE SIDE OF THE VEHICLE**

## STEP 7 - ROUTE THE AIR LINE

Cut the air line tubing into two equal lengths, making sure the tubing is cut as squarely as possible (a "saw" cut with a sharp knife is preferred). Select a location on the vehicle for the inflation valves. The location can be on the bumper or body of the vehicle, as long as it is a protected location so the valve will not be damaged, but maintain accessibility for the air chuck *see Figure "D"*. The inflation valve will be installed in step 8.

Insert the air line tubing into the push-to-connect fitting on the air spring as far as possible. Route the air line from the air spring to the desired inflation valve location.

With the tubing routed from the air spring to the location of the inflation valve use the nylon ties supplied to secure the air line tubing to the vehicle as shown in *Figure "D"*. Be careful to avoid heat and sharp edges when fastening the tubing to the vehicle. Route the tubing away from the exhaust system.

## STEP 8 - INSTALL THE INFLATION VALVE

Drill a 5/16" hole and install the air inflation valve using two 5/16" flat washers as supports *see Figure "E"*. Run the tubing from the air helper spring to the inflation valve, routing it to avoid direct heat from the exhaust pipe and away from sharp edges.

Cut the excess air line tubing so that it will fit easily into the inflation valve, making sure the end is cut squarely (a "saw" cut with a sharp knife is preferred). The air line tubing should not be bent or curved sharply, as it may buckle. Secure the tubing in place with the nylon ties provided. Push the end of the air line tubing into the inflation valve *see Figure "E"*.

## STEP 9 - INFLATE AND TEST

Inflate the air springs to recommended maximum operating pressure (see page 1 for operating pressures). With an applied solution of soap and water, check for air leaks around the fittings and valve core. Replace the wheels and torque the lug nuts to the manufacturer's specification. Jack the vehicle up, remove the jack stands, and lower the vehicle to the ground. Remove the wheel chocks from the front wheels. Reattach the negative battery cable. We recommend inflating and deflating in 5 p.s.i. increments to find the ideal riding condition for your vehicle.

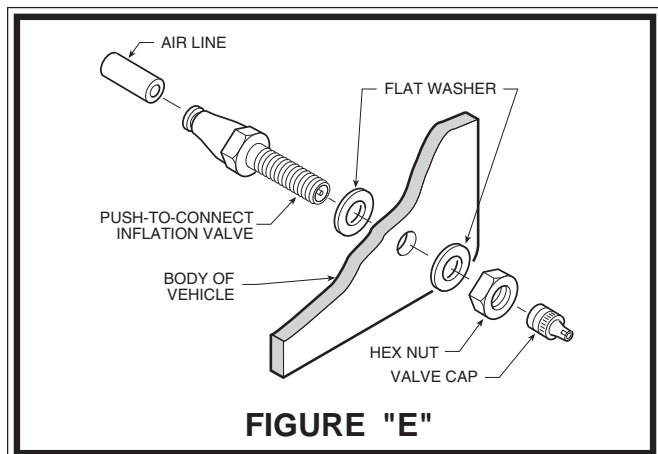
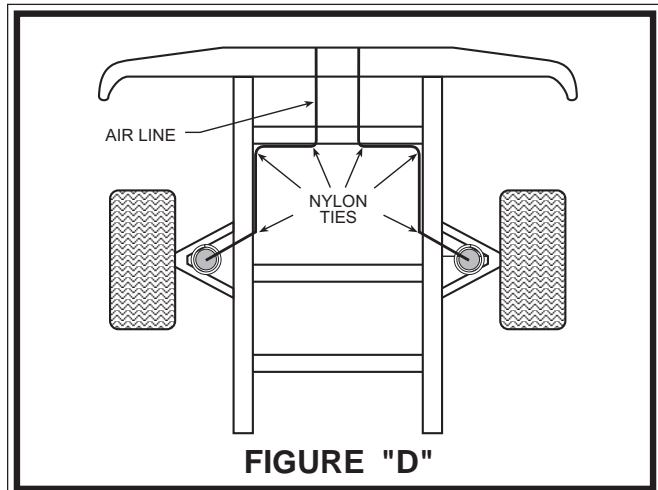
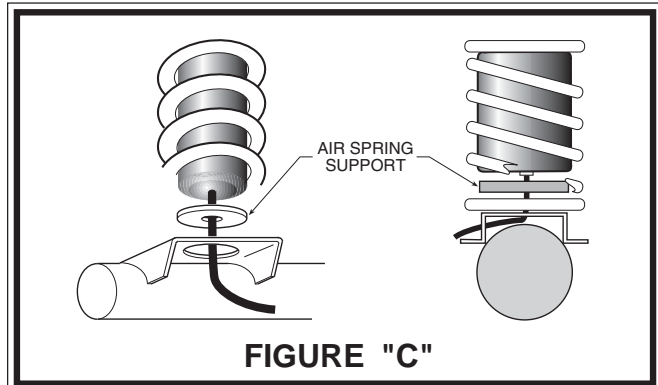
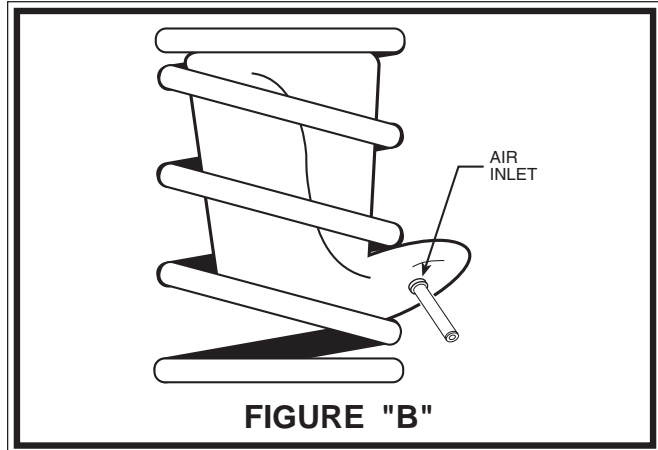

---

**NOTE: CHECK AIR PRESSURE ON A MONTHLY BASIS.**

---

**PLEASE TAKE ALL NECESSARY SAFETY PRECAUTIONS WHEN INSTALLING YOUR COIL-RITE KIT.**



# Do Not Return This Product to the Dealer or Distributor

## If you are

- missing parts,
- experiencing installation problems, or
- have technical concerns regarding this product,

you may contact a Firestone Technical Service Representative at [rrtech@fsip.com](mailto:rrtech@fsip.com) or at 800-888-0650 (option 1, and then option 2). Representatives are available from 7:30 a.m. – 4:30 p.m. Eastern on Monday – Friday, excluding holidays. If you are located outside of the United States, you should first contact your distributor or dealer directly with any issues.

When contacting Technical Service, please have the kit or part # ready, along with the make, model, and year of the vehicle. You may also need to provide details, such as 2WD/4WD or if the vehicle has been lifted or lowered from stock height.

If you have a warranty concern, please include in your email a detailed description of the situation, a photo(s) of the issue, and your contact information, including ship-to address.

**WARRANTY COVERAGE\***— The Ride-Rite™ kits, components, and accessories are warranted against defects in workmanship and materials. This warranty does not cover service or labor charges, neglect...to the product.

### **PERIOD OF COVERAGE:**

- |   |  |
|---|--|
| • Ride-Rite air springs – Lifetime Limited  | • Work-Rite load assists – 2 Years Limited                                       |
| • Sport-Rite air springs – Lifetime Limited | • Air-Rite accessories – 2 Years Limited   |
| • Coil-Rite air springs – Lifetime Limited  | • Brackets, hardware, fittings, air line, and other components – 2 Years Limited |
| • Level-Rite air springs – Lifetime Limited |  |

**HOW TO MAKE A WARRANTY CLAIM** — If you purchased your air springs in the U.S. or Canada and believe you have a part with a warrantable defect, call Firestone directly at 1-800-888-0650.

International customers should contact their distributors or dealers directly with any problems.

(\*) Please refer to the “Firestone Limited Lifetime Air Spring Warranty” for details, terms, and conditions.

## **WARRANTY QUESTIONS**

Go to [www.riderite.com/installation-support](http://www.riderite.com/installation-support)  
Select “Warranty Info” tab